

ARTOME X10



General specs

Name	Artome X10M
Materials	Birch plywood, MDF, steel, aluminum, tempered glass, polyester fabric
Dimensions	(W x H x D) 52 cm x 96,5 cm x 52 cm
Frame color	Black
Door color	Black (Default)
Weight (excl. projector)	46 kg
Warranty	2 years (extendable to 5 years)*

Technical specs

Power inlet	100-240V~ 50/60Hz, 7A (fused)
Power outlet	100-240V~ 50/60Hz, 2A
Power consumption (excl. projector)	75W
Sound	2.1-speaker system. Max. SPL 99 dB @ 1 m
Operating temperature	0-30 °C
19" rack	3U x 11" (depth)
Controls	Power, Source, Vol +/-, AV Mute, Freeze, Mic gain
Bluetooth Remote	Yes
Artome Connect App Compatible	Yes
Automatic Projector Provisioning	Yes

Connections

Front panel	HDMI, USB-B, USB-A (5V=1A), 2 x XLR Mic in with Level Control 2 x XLR out, Power outlet (100-240V~ 50/60Hz, 2.0A)
Back panel	HDMI, Audio in 3,5 mm, 2 x Customizable passthrough slots for D-type connectors
Top panel	USB-A (5V=1A)
Projector	All unused connectors can be accessed

Projector specs

Compatible projectors	VMZ7ST, VMZ6ST, VMZ82, VMZ72, VMZ62 VMZ71, VMZ61, VMZ51
Brightness	5200-8000 lm
Power consumption max.	420 W
Resolution	WUXGA (1920 x 1200)
Recommended image size	80-250"
Weight	7.0-8.4 kg



*The purchaser must activate the five (5) year warranty within six (6) months of purchase by registering the product at www.artomeinstaller.com

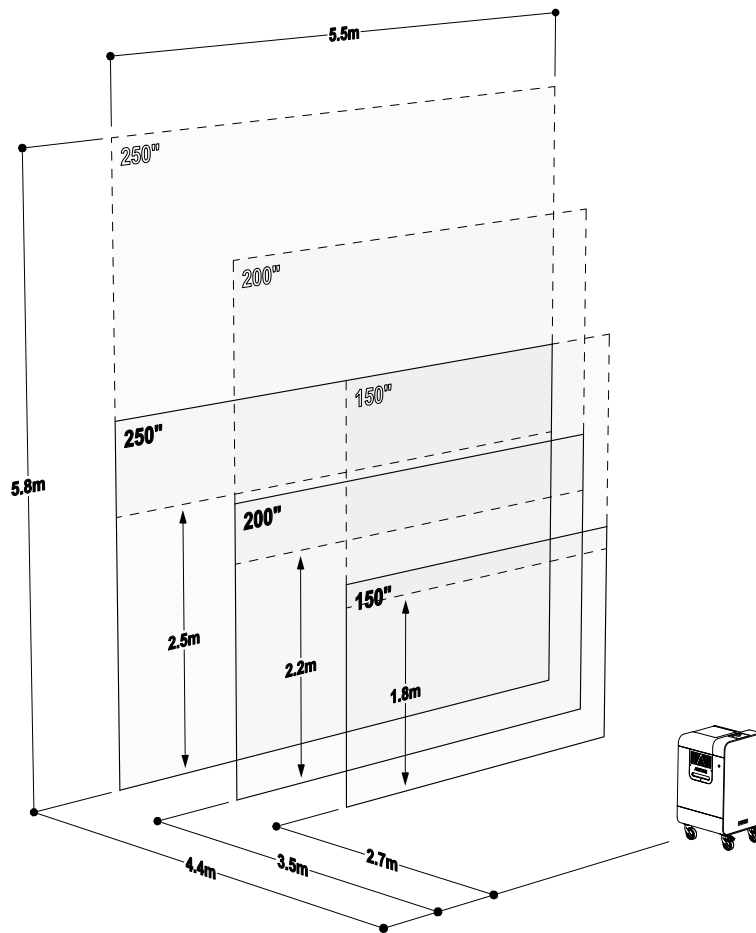

Example of projection distances with the Panasonic PT-VMZ7ST projector



- 1. Door
- 2. Control panel
- 3. Speakers
- 4. Lock
- 5. Fans
- 6. Lift handles

- 7. Projector angle adjustment
- 8. 19" rack
- 9. Connection panel
- 10. Cable storage space
- 11. Lockable castors
- 12. Cable pass-through

- 13. Projector adjustment hatch
- 14. Back connection panel
- 15. Subwoofer
- 16. Main power