

ARTOME X20

User manual



TABLE OF CONTENTS







Important safety	3
Symbols printed on the product	3
Symbols used in this document	3
Cautions and warnings	4
Terms and acronyms	6
Over current protection device	6
Product description	7
Intended use	7
Product overview	8
Video projector	9
Sound system	9
Artome HybriDock	9
User interface and connections	10
Control panel	10
Connection panel	11
Power connector	11
Remote control	12
Basic operations	12
Long press functions	13
Switching audio input mode	13
Enabling image adjustments mode	13
Pairing the Remote Controller	13
Artome Connect App	14
Operating instructions	15
Getting started	15
Video conferencing	15
Audio-only mode	15
Power off	15
Connecting additional devices to Artome	16
Camera	17
Microphone	17
Speakerphone	17
External sound system	17
Wireless sharing devices	17
Image adjustment	18
Image size	18
Keystone, zoom, lens shift and focus	19
Recommended Projector Lenses	19
Maintenance	20
Cable management	20
Cleaning the unit	20
Exterior	20
Interior	20
Door upholstery	20
Vacuuming the projector space and fans	20
Cleaning the lens	21
Projector air filter replacement	21
Fuse change	21
Product service program	21
Technical data	22
General specs	22
Technical specs	22
Connections	22
Projector specs	22
Troubleshooting	23
Power	23
Image	23
Audio	24
Peripherals	24
Support	24
Warranty	24
Disposal	25
Disposal of electronic components	25
Disposal of packaging waste	25

IMPORTANT SAFETY





Read and understand this manual and its safety instructions before using this product. Failure to do so can result in serious injury or death.

- Follow all the instructions to avoid electric shocks or other hazards that may result in property damage and/or severe or fatal injuries.
- To use this product, you must fully read and understand the contents of this user manual.
- To connect the cart with additional appliances, such as microphones, external speakers, and wireless collaboration devices, you must fully read and understand the contents of this user manual.
- Keep all safety information and instructions for future reference and pass them on to the next users of the product.













Symbols printed on the product

	Risk of electric shock Electrical voltages inside the Artome unit can cause a fire, electrical shock, or severe injury.
	Caution Do not open the Artome User Panel, Connection panel or Power panel. Never attempt to disassemble or modify the Artome unit (including installed projector). For service, refer to qualified service personnel.
	Class 1 Pluggable equipment Type A The equipment must be connected to an earthed mains socket-outlet.
	Waste Electrical and Electronic Equipment (WEEE) Dispose the product correctly at the end of its life to help protect the environment. Please refer to your local regulations for proper disposal instructions.
	Read user manual Read and understand the manual and its safety instructions before using this product.
	CE mark Declaration that the product complies with the essential requirements of the relevant European health, safety and environmental protection legislation.
	FCC mark Declaration that the electromagnetic radiation from the device is below the limits specified by the Federal Communications Commission and the manufacturer has followed the requirements of the Supplier's Declaration of Conformity authorization procedures.

Symbols used in this document

				
Caution	Risk of electric shock	Mandatory action	Do not do	Do not disassemble
				
Do not use in wet areas	Do not wet	Don't place on an uneven surface	Do not spray	Disconnect from the power outlet

Cautions and warnings

	<p>Unplug the unit from the outlet and contact qualified service personnel in the following situations:</p> <ul style="list-style-type: none"> • Smoke, unusual odors, or abnormal noises come from the unit or the projector inside it. • Liquid or foreign objects enter the unit or the projector inside it. • The unit has been damaged. <p>Continuing to use the unit in these conditions may cause electric shock or fire. Do not attempt to repair the unit yourself. Place the unit near an easily accessible outlet so the plug can be removed immediately in case of malfunction.</p>
	<p>Caution: Installation and removal of the projector from the unit must always be carried out by an instructed person. Incorrect installation may prevent the product from operating properly or cause malfunctions. If an instructed person is not available, contact your dealer to carry out the installation.</p>
	<p>Caution: Do not plug the unit into a power outlet until the projector is installed and the unit is fully configured. Otherwise, the product may be damaged or accidents and personal injury may occur.</p>
	<p>Do not look into the projector lens when the Artome unit is on. The bright light can damage your eyes. Groups with small children should be especially careful.</p>
	<p>Never open the User Panel, Connection Panel, or Power Panel. Do not attempt to disassemble or modify the unit (including the installed projector). Dangerous voltages inside the unit may cause fire, electric shock, or serious injury.</p>
	<p>Operate the product only with the voltage specified on the unit's power connector or in the user manual. Using any other voltage may cause damage and void the warranty. If unsure, contact your distributor or retailer.</p>
	<p>The voltage of the power outlets is same as the input voltage. This product is intended to be operated only using the voltages listed on the units main power connector or user manual. Operation using incorrect voltage could result in fire or electric shock.</p>
	<p>Do not use the unit where it may be exposed to rain, water, or excessive humidity. Fire or electric shock may result.</p>
	<p>Use only the power cord supplied with the unit. Using an unsuitable cord may result in electric shock or fire.</p>
	<p>Take care when handling the power plug.</p> <p>Failure to comply with these precautions could result in fire or electric shock. Follow these precautions when handling the power plug.</p> <ul style="list-style-type: none"> • Do not overload wall outlets, extension cables, or power strips. • Do not insert the plug into a dusty outlet. • Insert the plug firmly into the outlet. • Do not hold the plug with wet hands. <p>Do not pull the power cord when disconnecting the plug; always be sure to hold the plug when disconnecting it.</p>
	<p>Do not use a power cord that is damaged. Fire or electric shock may result.</p> <p>Follow these precautions when handling the power cord:</p> <ul style="list-style-type: none"> • Do not modify the power cord. • Do not place heavy objects on top of the power cord. • Do not bend, twist or pull the power cord excessively. • Keep the power cord away from hot electrical appliances. • Do not tie the power cord to other cables. <p>If the power cord is damaged, contact your dealer.</p>
	<p>Do not place containers of liquids or chemicals on top of the unit. Spills may enter the electronics and cause fire or electric shock.</p>

	Do not insert flammable or foreign objects into the unit's vents or openings. This may cause fire, electric shock, or burns.
	Do not use sprays containing flammable gas to clean parts such as the projector lens or fans. The projector inside the unit becomes hot during use, and the gas may ignite and cause a fire.
	Do not use the projector in places where flammable gases or explosive gases may be present in the atmosphere.
	Do not use high pressure air (air compressor or equivalent) to clean the unit. Very high air pressure may damage the unit.
	During use, do not block the projector light. Blocked light can heat the projection area, causing melting, burning, or fire. Reflected light may also overheat the lens and cause the projector to malfunction.
	Do not use the unit without locking the castors. In an earthquake or if the unit moves unexpectedly, it may collide with a person, wall, or object, causing serious injury or damage to the unit.
	Do not move or place the unit on an uneven surface. The product may topple or slide on a slope, causing accidents or injury.
	Do not sit or lie on top of the unit. Falling may cause serious injury.
	Do not use the unit when someone is close to it. High sound pressure levels may cause permanent hearing damage.
	Do not walk behind the product when the power cord is plugged in. A loose cord can cause a fall and serious injury.
	Do not connect video or audio connectors when the unit is on. This may cause high sound pressure which can cause permanent hearing damage
	Always feed external cables through the cable grommet at the bottom of the unit and close the door. Cables may break due to incorrect pressure on the connectors.
	Do not store the device without proper protection from dust. The dust may damage the product when it is used again. Use included carton box for storing.
	Do not move the unit on uneven or rough surfaces. The castors may be damaged.

Terms and acronyms

Term or acronym	Description
2.1. audio	Loudspeaker system consisting of two front speakers and a subwoofer for low bass sound.
Active speaker	A loudspeaker with an integrated amplifier.
AEC	Acoustic Echo Cancellation
Bluetooth connection	Wireless short range data connection.
Cardioid microphone	Microphones that pick up sounds with high gain from the front and sides but poorly from the rear.
DSP	Digital Signal Processor. Digital technology to enable versatile sound processing.
HDMI	High-Definition Multimedia Interface. An audio/video interface for transmitting uncompressed video data and compressed or uncompressed digital audio data.
HybriDock™	An USB audio interface which converts analog audio sources, such as microphones to digital USB microphones and transmits USB audio from a laptop to the Artome sound system.
Keystone effect	The apparent distortion of an image caused by projecting it onto an angled surface.
Phantom power	DC electric power transmitted through microphone cables to operate microphones that contain active electronic circuitry.
Subwoofer	Loudspeaker for low bass sounds.
USB dongle	A dongle is a small piece of computer hardware that connects to a port on another device to provide it with additional functionality, or enable a pass-through to such a device that adds functionality.

Over current protection device

The protective current ratings reflect the overcurrent protective devices provided in the building installation. Ensure that the appropriate devices are in place to meet safety standards.

For equipment intended for use in most countries, the protective current rating of the circuit supplied from the mains is considered to be 16 A. However, different countries have specific variations:

United States and Canada: The protective current rating is considered to be 20 A.

United Kingdom and Ireland: The protective current rating is 13 A, corresponding to the largest fuse rating used in mains plugs.

France: In certain cases, the protective current rating is considered to be 20 A instead of 16 A.

PRODUCT DESCRIPTION

The cart integrates a high-quality projector and sound system into a portable unit, offering professional AV capabilities with minimal setup required. Designed for flexible use in educational facilities and business environments, the cart enables hybrid interactions, allowing seamless engagement for both in-person and virtual scenarios.

Intended use

The cart is designed for use as a local presentation device or as a mobile all-in-one solution in various video conferencing environments. This product features a pre-installed projector for displaying scalable image and a built-in sound system comprising an embedded mixer and an active speaker system, as well as connections for video conferencing devices.

**CAUTION**

Do not use the cart outdoors. Check the allowed temperature ranges in technical specifications.

The Artome X20 is compatible with the following Epson projector models:

Epson EB-PU1006W / 1007W / 1007B / 1008W / 1008B / 2010W / 2010B

The User Guide of the selected projector is provided with Artome X20 if it is included in Epson's package.

**CAUTION**

This cart is intended for use only with the projector models mentioned above. Use with other equipment may result in instability causing injury.

Product overview

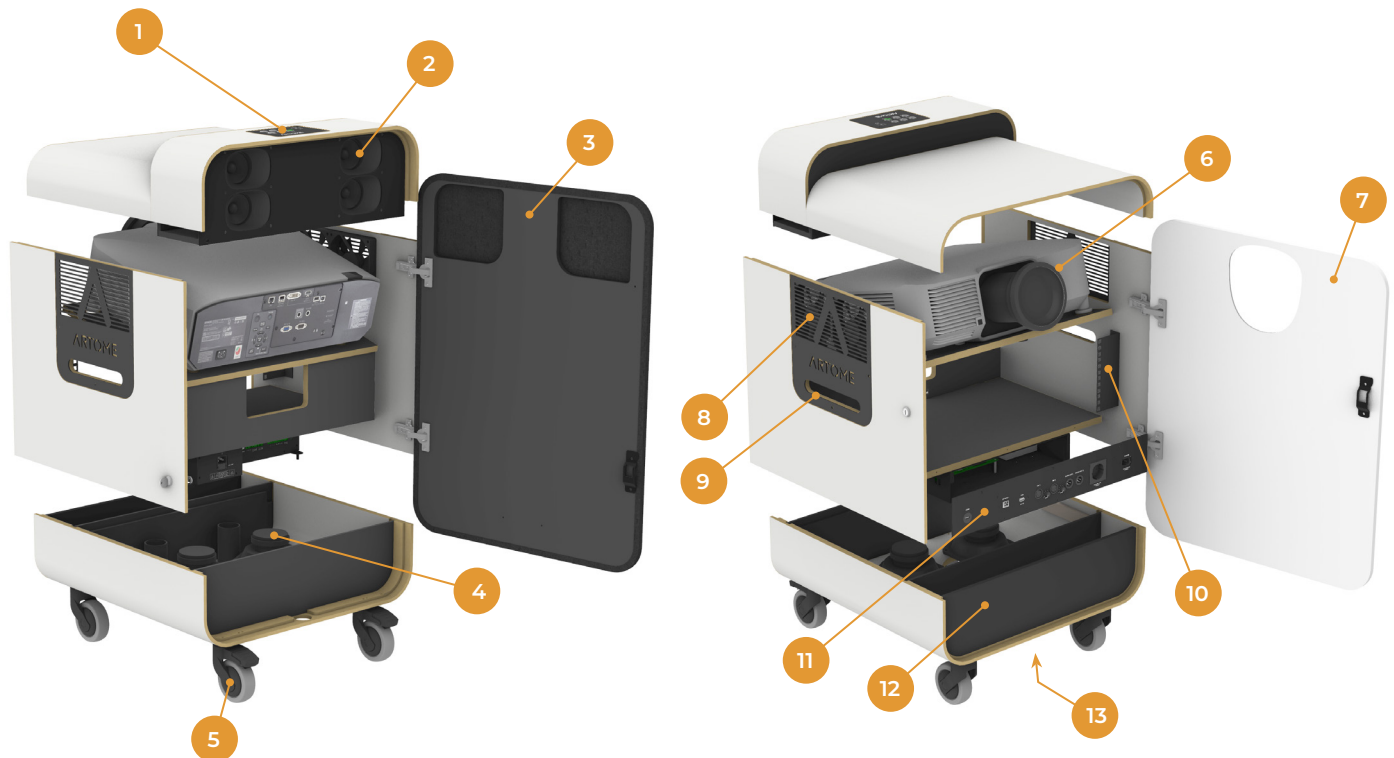

1. Control panel for controlling the Artome and the Epson projector
2. Speakers
3. Front door
4. Subwoofer speaker
5. Casters
6. Epson projector (external device that is sold separately)
7. Push-to-open back door
8. Fan for projector air ventilation
9. Handles for moving the product
10. 19" rack for auxiliary devices
11. Connection panel with mains power in and connections for audio and video transmission
12. Storage compartment for cables and accessories
13. Cable grommet for cable management

Video projector

The image features of the cart are powered by integrated laser projector technology. All these features are accessible through the projector's user interface. However, essential functions such as Projector On/Off, Freeze and AV Mute can be controlled via the cart user interface. If the projector is activated using the projector's user interface or by a third-party system, the cart detects the action and powers on accordingly.

The cart ensures proper ventilation for the projector, allowing cool air to enter and warm air to exit through its built-in ventilation system. Additionally, the projector is equipped with a temperature sensor as a safety precaution.

Sound system

The cart features a built-in active speaker system with two front speakers and a subwoofer, providing a 2.1 audio setup. Additionally, it is equipped with two XLR outputs for connecting external speakers or transferring signals to other sound systems. The device also supports plug-and-play connections to microphones. Sound processing is handled by the Artome Digital Signal Processor (DSP) and amplified through the embedded D-class amplifier.



Please note that sound quality may vary based on room size and acoustics. Testing the system in a specific location is recommended. If extra amplification is necessary, use the Audio Out connection to link to additional speakers or sound systems.

Artome HybriDock

The Artome HybriDock serves as a USB audio interface, converting analog sources MIC 1 & MIC 2 into a digital USB signal. It also operates as a digital output device for audio playback through Artome speakers. Additionally, the HybriDock enables connectivity between USB peripherals and your computer.

USER INTERFACE AND CONNECTIONS

Control panel

Easy-to-use button controls allow for simple operation of the device. The panel also features a USB 3.0 connector for connecting external devices, such as cameras or microphones, to the Artome HybriDock.

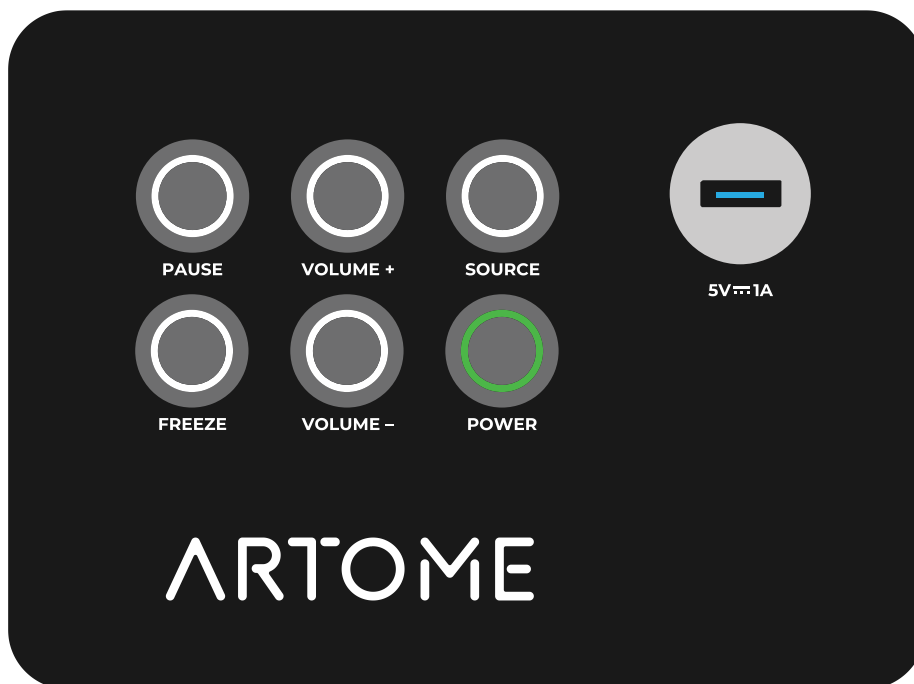



Button	Indicator	Action	LED	Description
PAUSE		Short press: Pause on / off	On	AV-mute on
		Long press: Activate bluetooth pairing	Blinking	Bluetooth pairing mode active
			Off	AV-mute off
FREEZE		Short press: Image freeze on / off	On	Image freeze active
			Off	Image freeze off
VOLUME +/-		Short press: Adjust volume by 1 digit	Blinks once	Indication of a volume adjustment
		Long press: Continuously adjust volume		
SOURCE		Short press: Change source	On	Audio-only -mode is active. POWER led is also on.
		Long press: Activate Audio-only -mode	Blinking	Transitioning to Audio-only -mode.
POWER		Short press: Power on / off	On	Power on
		Long press: Image settings reset	Blinking	Warming up / cooling down
			Off	Power off

Connection	Description
USB	Connection for additional devices (e.g. a USB camera)

Connection panel

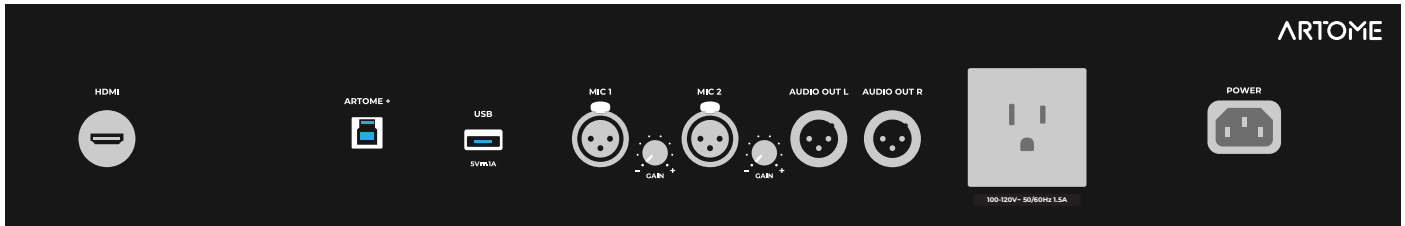
The connection panel contains standard ports for transmitting video and audio data. These ports are designed for various purposes such as local presentations, streaming, or video conferencing. The control panel is positioned behind the back door. To open the back door, unlock the door and press the top left corner to activate the push-to-open mechanism.



Connection	Description
HDMI	Audio and video input
ARTOME +	USB uplink to computer. Makes all devices connected to Artome's USB ports visible on the computer.
USB	Connection for additional devices (e.g. a wireless speakerphone receiver)
MIC 1 & 2	Connection for a wired microphone or a wireless microphone receiver (input level switchable between MIC and Line)
GAIN	Mic gain adjustment
AUDIO OUT L & R	Audio output for external speakers (balanced stereo 0 dBV)
POWER SOCKET	Power distribution to peripherals (e.g. a wireless casting device or a mini pc)
	The power outlet socket is located inside the product and can be accessed by opening the front door. Ensure that this door is not obstructed and can be easily opened at all times to allow for quick disconnection of the equipment if necessary.
POWER	Mains power input

Power connector

The power connector is located on the connection panel. The control panel is positioned behind the back door. To open the back door, simply press the top left corner to activate the push-to-open mechanism.

REMOTE CONTROL

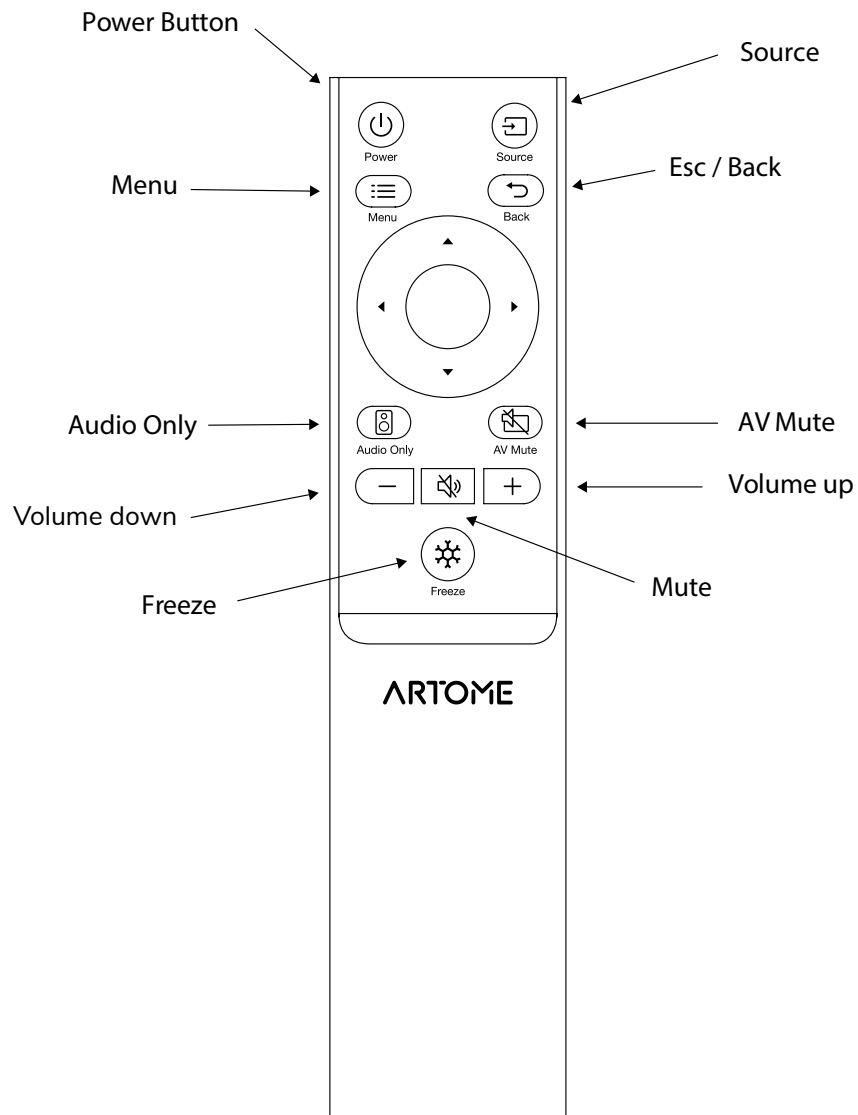

Basic operations

Power On/Off	Use the power button to turn the Artome unit on or off.
Source	Select the input source.
Menu	Access the projector menu.
Esc / Back	Go back or exit the current projector menu.
Volume Control	Adjust the volume using the + and - buttons.
Freeze	Freeze the video.
Audio Only	Switch to audio-only mode.
AV Mute	Press the AV Mute button to mute both audio and video.

Long press functions

Switching audio input mode

1. Long-press **MUTE** 10 for seconds to enable input mode selection

- Mic mode is the default

2. Use **Up/Down arrow keys** to toggle between modes.

- **Power LED blinking** = Mic mode
- **Source LED blinking** = Line In mode

! When the **Source LED is blinking**, adjust input gain with the **Left/Right arrow keys**.

3. Press **MUTE** to confirm the selection.

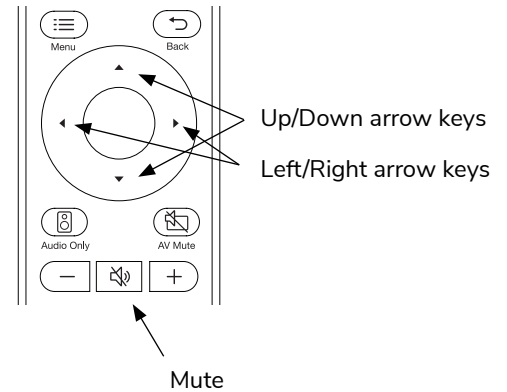

Enabling image adjustments mode

1. Long press **FREEZE** to enable image focus mode

2. Adjust focus with the **Left/Right** arrow keys

Press and hold **FREEZE** to enter lens adjustments. Pressing the button again cycles through Focus » Lens Shift » Zoom. Make adjustment with navigation buttons.

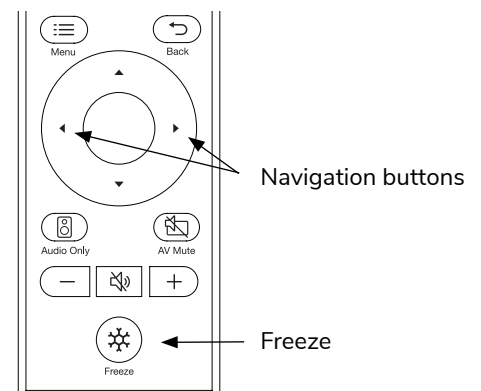

Pairing the Remote Controller

	<p>Note: If the Artome unit has been updated or reset to factory settings, the remote controller may need to be paired again. Follow the pairing instructions to perform the pairing.</p>
---	---

1. Set Artome unit in pairing mode:

- Press and hold **PAUSE** on the Artome unit for 3 seconds.
- The **AV MUTE LED** will flash, indicating it is ready to pair.

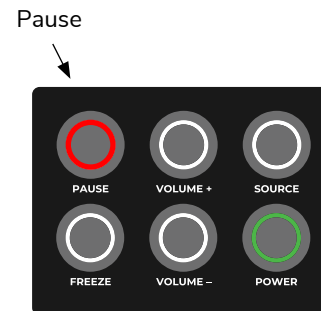

2. Set the Remote Controller in pairing mode:

- Press and hold **Audio Only** and **AV Mute** on the remote simultaneously for ~5 seconds.
- When paired, the **Volume +** and **Volume - LEDs** on the Artome unit will illuminate for 2 seconds.

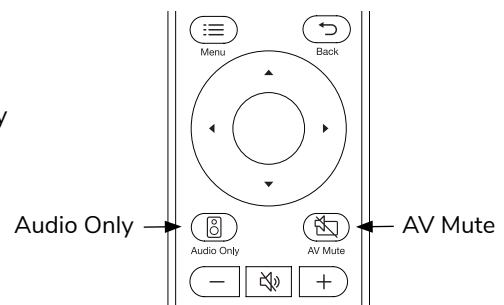

ARTOME CONNECT APP

The Artome Connect App is a tablet application that lets you control and customize your Artome device. With the app, you can:

- Control core features, just like with the remote.
- Fine-tune audio settings and explore advanced options unavailable elsewhere.
- Manage inputs and customize connections.
- Adjust security settings to enhance the safety of your device.

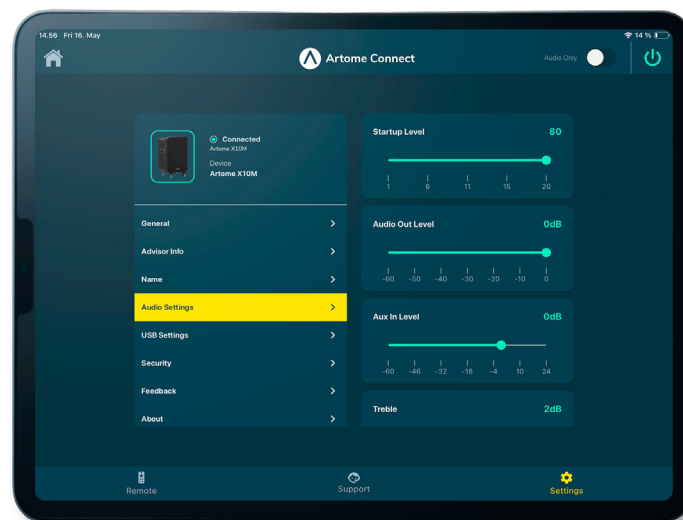
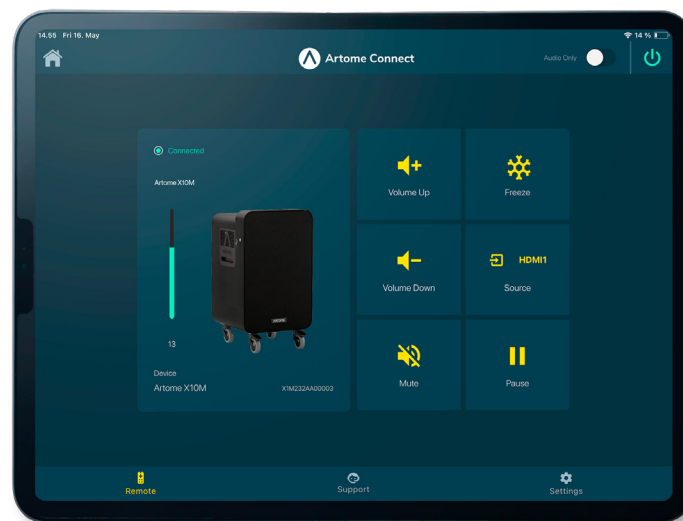

Download Artome Connect from the App Store or Google Play store.



OPERATING INSTRUCTIONS

Getting started



Connect the power cable to the power connector on the connection panel of the device.
Connect your laptop to the HDMI port on the connection panel using an HDMI cable.

Video conferencing

Connect the HDMI and USB-B cable to the Artome Hybridock inside the unit, and the other end to your laptop.



MICROPHONE

"The name of the speakerphone"

Uses speakerphone as the audio source

Artome Hybridock

Uses Artome MIC 1 or MIC 2 connection as the audio source

- the mic sound plays back from the Artome speakers in addition to the video call

SPEAKER

"The name of the speakerphone"

Speakerphone plays back the video call audio

Artome Hybridock (USB)

Artome speakers play back the video call audio

- Playback volume is controlled from the computer

EPSON-PJ (HDMI)

Artome speakers play back the video call audio

- Playback volume is controlled from the Artome

CAMERA

"The name of the USB camera"

Uses camera connected to Artome as the image source

Audio-only mode

Turn on Artome. Press the SOURCE button to select the desired source. Now, long-press the SOURCE button to activate Audio-only mode. The projector will shut down, but the speaker system stays on.



Long-press the SOURCE button to turn the projector back on. Press the POWER button to shut down the device.

Power off

Press the POWER button to shut down the device. Afterward, a cool-down period of up to 2 minutes for the projector follows, during which the Artome fans may still be running.

Connecting additional devices to Artome

The cart serves as a versatile mobile presentation solution and doubles as a rack for additional devices. With its all-in-one design, cabling is streamlined with short dimensions, making cable management effortless.

	<p>DISCLAIMER The peripherals mentioned below are not included with the device. They must be purchased separately.</p>
	<p>DISCLAIMER While this manual showcases sample configurations featuring additional devices, it does not provide instructions on how to utilize those supplementary peripherals.</p>

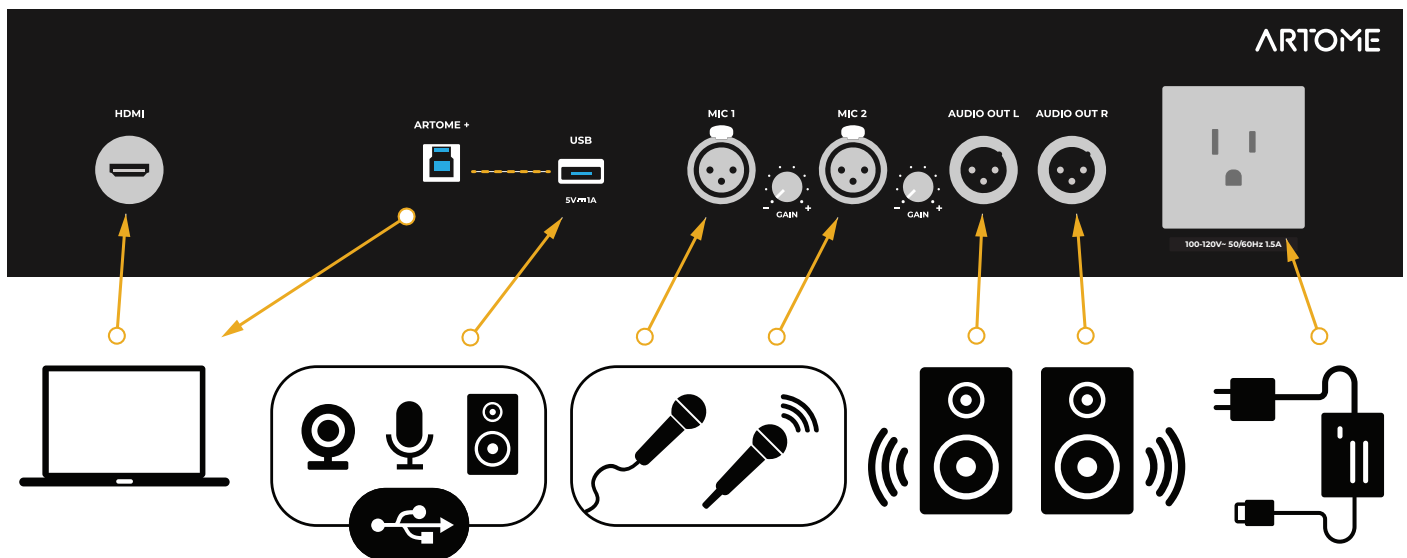

Connection	Device
AUDIO OUT L & R	Audio output for external speakers (<i>balanced stereo 0 dBV</i>)
MIC 1 & 2	Connection for a wired microphone or a wireless microphone receiver
HDBaseT	Connection for 3rd-party integration
HDMI	Computer image and sound to Artome
ARTOME +	Connection between computer and additional USB devices
USB	Connection for additional USB devices (<i>e.g. a camera, a conferencing microphone or a speakerphone receiver</i>)

Camera

Install a USB camera onto the top panel of the cart using a magnet-mounted camera leg, or in an appropriate location with an optional camera stand. Connect the camera to either USB port of the cart or directly to the host computer.



If you are using a USB 3.0 camera, please note that the cable length should not exceed 6 feet to ensure proper operation. For distances longer than 6 feet, Artome recommends using USB 2.0 cameras or a camera with an additional power supply.

Microphone

MIC 1 and MIC 2 connections support analog microphones. When selecting a microphone for cart, consider the following:

- Artome recommends dynamic cardioid (or hyper-/supercardioid) microphones to minimize feedback.
- For microphones with cables, input gain is fixed and optimized for dynamic microphones with an impedance of 350 ohms.
- The microphone input does not provide phantom power, so additional power supply is needed for condenser microphones.
- When using rack-mounted wireless microphones, ensure the microphone receiver depth does not exceed 11.2" (incl. the cable), and adjust the gain from the microphone system.

For recommendations on preferred microphones and wireless microphone systems, consult your Artome reseller.

Speakerphone

Artome recommends using speakerphones with Bluetooth USB dongles or long USB cables. Connect a wireless Bluetooth USB dongle or a USB cable to either USB port on the cart. Be sure to charge the speakerphone and turn it off after use.

External sound system

Artome includes stereo audio out connection for connecting additional sound systems or audio devices to Artome solution. Audio out signal is not processed, but signals are mixed with the embedded DSP mixer. Gain in Audio Out is 0 dB.



Note that by default the audio will play from Artome's speakers and Audio Out simultaneously. Use the Artome Connect app to adjust the audio settings, or use the gain controls on the external sound system to balance the volume levels between the Artome speakers and the external sound system.

Wireless sharing devices

Wireless sharing technology is not included by default, but the cart easily connects to any wireless collaboration system via HDMI.



This manual does not contain operating instructions from other vendors. For more details, please refer to additional guides provided by the manufacturer.

IMAGE ADJUSTMENT

Image size

The distance from the unit to the projection surface affects the image size. To increase the image size, move the X20 further away from the projection surface. To decrease the image size, move the unit closer to the projection surface.

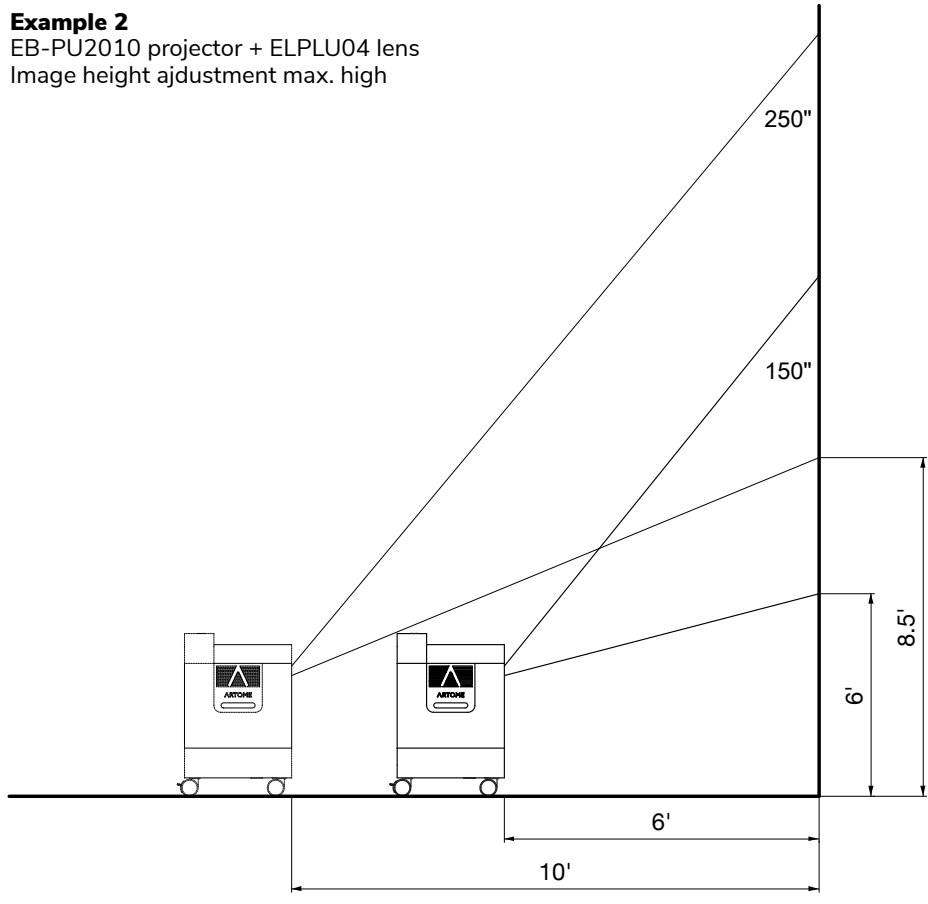
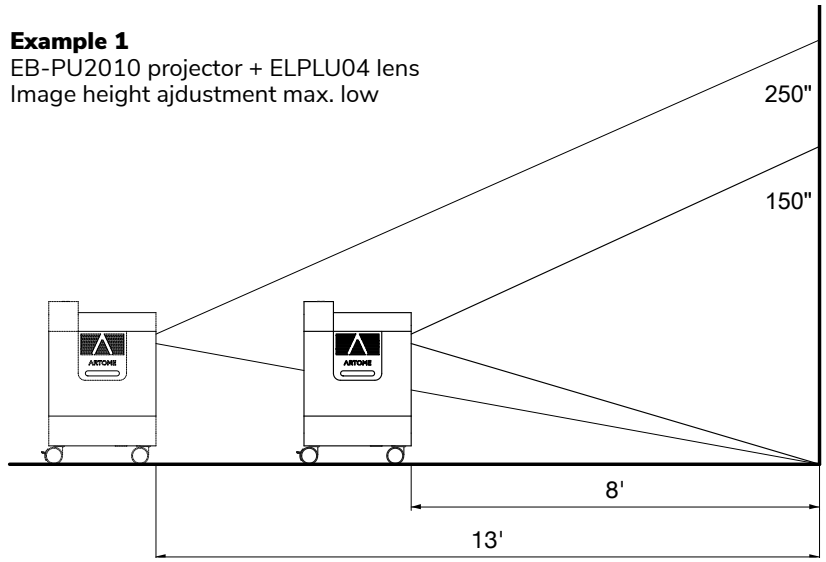

Keystone, zoom, lens shift and focus

T. Test Pattern

Select the Test Pattern mode and adjust the image with phases 1-4.

1. Lens shift

Adjusts the image position horizontally and vertically

2. Menu / Settings / Geometry Correction / H/V-keystone

V-keystone:

Adjusts the tilt angle of the image
(compare that the vertical edges are straight)

V-balance:

Adjusts the image height
(compare that the circular shapes of the Test Pattern are symmetrical)

3. Zoom

Adjusts the image size

4. Focus

Adjusts the image focus

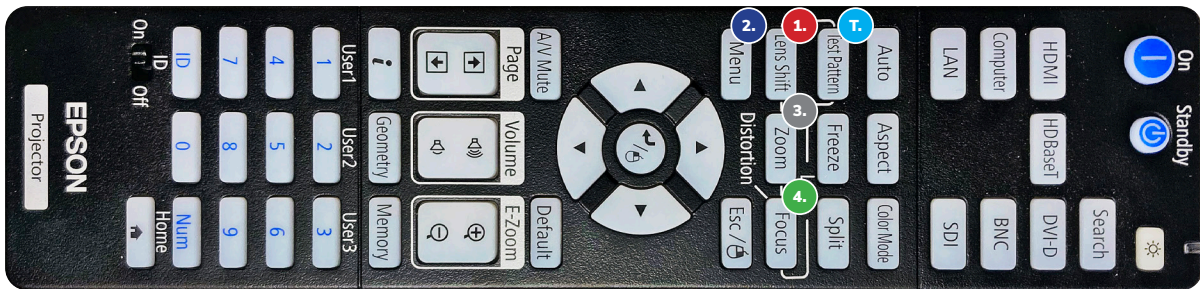

Recommended Projector Lenses

The unit accommodates a range of projector lenses, allowing for an optimal throw distance.

	The unit can house all lenses suitable for Epson EB-PU series projectors, except for the LPLX01S, LPLX020S, and ELPLU03SV.
--	--

EB-PU1000 Series

Lens	Part nr.	Throw Ratio	Throw Ratio Range											
			1.0	2.0	3.0	4.0	5.0	6.0	7.0	8.0	9.0	10.0		
Short	ELPLU04	0.87-1.05												
Wide	ELPLW06	1.62-2.22												
Middle	ELPLM15	2.16-3.48												
Long	ELPLL08	7.21-10.11												

EB-PU2010

Lens	Part nr.	Throw Ratio	Throw Ratio Range											
			1.0	2.0	3.0	4.0	5.0	6.0	7.0	8.0	9.0	10.0		
Short	ELPLU04	0.64-0.77												
Wide	ELPLW06	1.19-1.62												
Middle	ELPLM15	1.57-2.56												
Long	ELPLL08	5.27-7.41												

MAINTENANCE

Cable management

1. Disconnect any unnecessary cables and put them neatly inside the storage space.
2. Make sure that the necessary cables are firmly connected and enter the casing through the cable grommet.

Cleaning the unit

Exterior

1. Wipe the exterior surfaces (excluding the front door, the projector lens, and the user panel) with a damp cleaning cloth and neutral detergent.
2. After wet wiping, wipe the surfaces dry.



Keep the exposure time of chemicals on surfaces to the minimum and avoid excessive abrasion

Interior

1. Open the front door by pressing the top left corner to activate the push-to-open mechanism.
2. Wipe the interior surfaces with a dust-binding cleaning cloth.

Door upholstery

- Dry clean the fabric of the front door using a vacuum cleaner with an upholstery tool.



If the front door fabric gets damaged or stained uncleanable, please contact Artome Support for a spare part.

Vacuuming the projector space and fans



- Clean the projector casing with a vacuum cleaner equipped with a crevice nozzle. Clean under the projector and around the fans on both sides of the cabinet.



Dust may block air ventilation for projector and cause the projector warming up.

Cleaning the lens

- Clean the projector's lens periodically, or whenever you notice dust or smudges on the surface. Make sure you unplug the projector before cleaning the lens.
- To remove dust or smudges, gently wipe the lens with lens-cleaning paper.
- To remove stubborn smudges, moisten a soft, lint-free cloth with lens cleaner and gently wipe the lens. Do not spray any liquid directly on the lens.

	Do not use a lens cleaner that contains flammable gas. The high heat generated by the projector may cause a fire.
	Do not use glass cleaner or any harsh materials to clean the lens. Do not subject the lens to any impacts; you may damage it. Do not use canned air, or the gases may leave a residue. Avoid touching the lens with your bare hands to prevent fingerprints or damage to the lens surface.

Projector air filter replacement

Contact Artome Support for assistance, if an air filter needs to be replaced.

Fuse change

Artome Mains power connector uses a 5x20mm 10A fast acting fuse. Contact Artome Support for assistance, if a fuse needs to be replaced.

Product service program

Task	Frequency
Cleaning the furniture	Every month
Vacuuming the projector space and fans	Every month
Testing operation including all connections	Every 6 months
Projector air filter cleaning or replacement	Every 12 months

TECHNICAL DATA

General specs

Name	Artome X20
Materials	Birch plywood, MDF, steel, aluminum, polyester fabric
Dimensions	(W x H x D) 24.4 × 38.9 × 24.8"
Weight (excl. projector)	132 lb
Warranty (excl. projector)	2 years (extendable to 5 years)

Technical specs

Power inlet	100-120V ~ 50/60HZ 10A (Fused)
Power outlet	100-120V ~ 50/60Hz, 1.5A
Power consumption (excl. projector)	75W
Sound	2.1-speaker system. Max. SPL 114 dB @ 1m
Operating temperature	32–86 °F

3U full depth + 1U shallow depth		
	Rack rails at the inner position	Rack rails at the outer position
19" rack	Full depth: 14.1" Shallow depth: 7.9" Rack front: 4.65"	Full depth: 16.5" Shallow depth: 10.2" Rack front: 2.3"
Controls	Power, Source, Vol +/-, AV Mute, Freeze, Mic gain	
Bluetooth Remote	Yes	
Artome Connect App Compatible	Yes	
Automatic Projector Provisioning	Yes	

Connections

Front panel	1 x HDMI, 1 x USB-B, 2 x XLR Mic in with Level Control 2 x XLR out, 1 x USB-A, Power outlet (100-120V~ 50/60Hz, 1,5A)
Top panel	1 x USB-A (5V=1A)
Projector	All unused connectors can be accessed including 1 x HDMI in & 1 x HDMI out with EB-PQ2010/PQ2008

Projector specs

Compatible projectors	EB-PU1006 / EB-PU1007 / EB-PU1008 / EB-PU2010 / EB-PQ2008 / EB-PQ2010
Brightness	6000 / 7000 / 8000 / 8500 / 10000 lm
Power consumption	367 / 431 / 535 / 535 W
Resolution	WUXGA / 4K with EB-PQ2010 / PQ2008
Recommended image size	100-400"
Weight	44 lb

*The Purchaser needs to activate the five (5) year warranty within six (6) months from purchase by registering the product at artome.fi/en/warranty.



Artome does not assume responsibility for the performance, compatibility, or functionality of third-party products or their respective features. Users should refer to the documentation provided by the respective vendors for detailed information on their products.

TROUBLESHOOTING

Power

Error	Typical cause	Solution
Product does not start when pressing the power button.	Power cable is not connected correctly or there is no power in power outlet.	Check power cable connection. Check the cable for any damage and replace the cable if needed.
Product is powered correctly, but still does not start.	Power fuse of Artome is blown, or other power related issue.	Check if connection panel power sockets feed power by plugging in a laptop or other device. If power is not fed to laptop the fuse is burned. If power is fed to laptop, the fuse is not burned. In both issues, contact local Artome dealer or Artome service.
Overheat warning and projector turns automatically off.	Room temperature is too high, or Epson projector air filter is too dusty.	Ensure that room temperature is less than 30 °C / 86 °F and try again. If problem still occurs, air filter of projector might be dusty and requires cleaning or replacement. Contact local Artome dealer for service.
Projector fans occasionally run at high speed.	Projector is too hot and is cooling down.	Check the room temperature and the air filter mentioned above. If the issue persists contact local Artome dealer or Artome service.
Artome fans continue to run after the device has been turned off.	Fans are performing cooldown.	This is normal behavior to control the temperature of the device.

Image

Error	Typical cause	Solution
HDMI signal is not found even after SOURCE button is pressed.	HDMI cable is not connected, or HDMI cable or HDMI adapter is broken.	Check HDMI cable connection from Artome end and laptop end. Try with another HDMI cable, with another HDMI input and with different laptop.
Projector is showing wrong content.	There are multiple sources connected to Artome and the wrong source is selected as active.	Push source button to select the correct source.
Laptop is connected but can't see icons from my desktop.	Laptop recognizes Artome as extended display.	Change laptop display settings.
Image is too small.	Zoom/image lift function is decreasing the size of the image.	Long press Artome POWER button to reset image settings. Move the device further away from the projection surface.
Image is too low.	Image has not been lifted with zoom/lens shift function.	See page 13.

Audio

Error	Typical cause	Solution
Laptop volume is not adjusting Artome volume.	With Apple computers there is no volume adjustment in HDMI output.	Connect USB cable and use Artome HybriDock as output device.
Artome volume buttons don't adjust mic volume from Artome speakers.	This is by design.	Mic volume can be adjusted from the Mic Gain control.

Peripherals

Error	Typical cause	Solution
There is feedback in microphone connected to MIC1 or MIC2.	Microphone sensitivity is too high or input gain too high.	Adjust mic gain from Artome. Move the microphone further away from the speakers.
No audio from microphone connected to MIC1 or MIC2.	Input gain set too low or microphone is turned off.	Attach microphone cable. Adjust mic gain from Artome. Check that microphone is not turned off.
Microphone connected to MIC1 or MIC2 is not heard by remote party.	Wrong input in videoconferencing software settings.	Select Artome HybriDock as input device.
Microphone connected to USB is not heard from Artome speakers.	This by design.	USB microphones are only usable by connected computer.
USB camera or USB speakerphone is not working.	Laptop is not connected to Artome with USB.	Check that USB cable is connected correctly between Artome+ connector and laptop.
USB peripherals not receiving power	By default: if no computer is connected USB devices don't receive power.	Either connect a computer to Artome+ connection or toggle persistent USB power supply active from the Artome Connect app
USB camera is not working when using longer USB cable.	If the camera requires USB 3.0, maximum length for cable is 1.8 m/6ft to power the camera.	Use USB 2.0 camera or USB camera with separate power supply.

SUPPORT

To contact Artome Support email support@artomeusa.com or visit support.artomeusa.com.

WARRANTY

Artome warrants that the Artome X20 it manufactures is free from defects in materials and workmanship. The standard warranty period is two (2) years from the date of delivery. If the Product is registered within six (6) months from the shipping date, the warranty period is extended to five (5) years from the date of delivery. Register at: artome.fi/en/warranty

For warranty claims, please contact Artome Support.

DISPOSAL

Disposal of electronic components



Waste Electrical and Electronic Equipment (WEEE)

Dispose the product correctly at the end of its life to help protect the environment. Please refer to your local regulations for proper disposal instructions.

The symbol on the product indicates that this device must not be treated as unsorted municipal waste but must be collected separately! Dispose of the device via a collection point for the recycling of waste electrical and electronic equipment if you live within the EU and in other European countries that operate separate collection systems for waste electrical and electronic equipment. By disposing of the device in the proper manner, you help to avoid possible hazards for the environment and public health that could otherwise be caused by improper treatment of waste equipment. The recycling of materials contributes to the conservation of natural resources. Therefore, do not dispose of your old electrical and electronic equipment with the unsorted municipal waste.

Disposal of packaging waste

The packaging is made of environmentally friendly materials, which may be disposed through your local recycling facilities. By disposing of the packaging and packaging waste in the proper manner, you help to avoid possible hazards for the environment and public health.